

Specifications

Nominal Voltage		12 V
Capacity (25°C)	10HR(10.8V)	80 Ah
	5HR(10.5V)	70Ah
	1HR(9.60V)	49.6Ah
Dimension	Length	350 ± 2mm (13.78inch)
	Width	167 ± 2mm (6.57inch)
	Height	179 ± 2mm (7.05inch)
	Total Height	T5: 186 ± 2mm (7.32inch) T9: 179 ± 2mm (7.05inch)
Approx. Weight		23.2kg (51.0lbs) ± 4%
Terminal type		T5/T9
Internal resistance (Fully charged, 25°C)		Approx. 4m Ω
Capacity affected by temperature (10HR)	40°C	102%
	25°C	100%
	0°C	85%
	-15°C	65%
Self-discharge (25°C)	3 month	Remaining Capacity: 91%
	6 month	Remaining Capacity: 82%
	12 month	Remaining Capacity: 65%
Nominal operating temperature		25°C ± 3°C (77°F ± 5°F)
Operating temperature range	Discharge	-15°C ~ 50°C (5°F ~ 122°F)
	Charge	-10°C ~ 50°C (14°F ~ 122°F)
	Storage	-20°C ~ 50°C (-4°F ~ 122°F)
Float charging voltage(25°C)		13.50 to 13.80V Temperature compensation: -18mV/°C
Cyclic charging voltage(25°C)		14.50 to 14.90V Temperature compensation: -30mV/°C
Maximum charging current		24A
Terminal material		Copper
Maximum discharge current		800A(5 sec.)
Designed floating life(20°C)		12 years

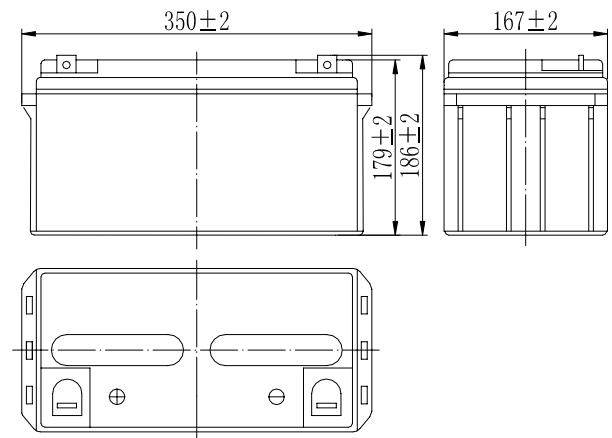

Dimensions



Terminal

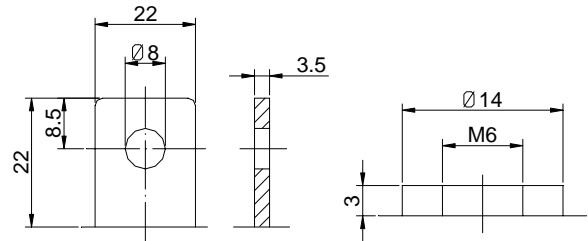

Terminal T5

Terminal T9

- ◆ Absorbent glass mat technology;
- ◆ Recognized by UL & CE;
- ◆ ABS container.

Constant Current Discharge Characteristics (A, 25°C)

F.V/TIME	10min	15min	30min	60min	2h	3h	4h	5h	8h	10h	20h
9.60V	168	132	80.0	49.6	29.2	20.4	16.7	14.3	9.79	8.14	4.28
9.90V	163	129	78.4	48.9	29.1	20.3	16.6	14.2	9.73	8.13	4.27
10.2V	156	124	76.0	47.6	28.8	20.1	16.5	14.1	9.67	8.10	4.25
10.5V	150	120	74.2	46.7	28.4	20.0	16.4	14.0	9.60	8.06	4.23
10.8V	141	114	71.4	45.2	27.6	19.4	15.9	13.6	9.31	8.00	4.20

Constant Power Discharge Characteristics (Watt, 25°C)

F.V/TIME	10min	15min	30min	60min	2h	3h	4h	5h	8h	10h	20h
9.60V	1814	1449	898	565	339	240	197	169	116	97.2	51.3
9.90V	1760	1415	880	557	337	238	196	168	116	97.0	51.2
10.2V	1687	1362	853	543	334	237	194	167	115	96.8	51.1
10.5V	1615	1316	832	532	329	235	193	165	114	96.2	50.8
10.8V	1524	1246	802	516	320	228	187	161	111	95.5	50.4

Note: The above characteristics data can be obtained within three charge/discharge cycles.

Discharge Characteristics(25°C)

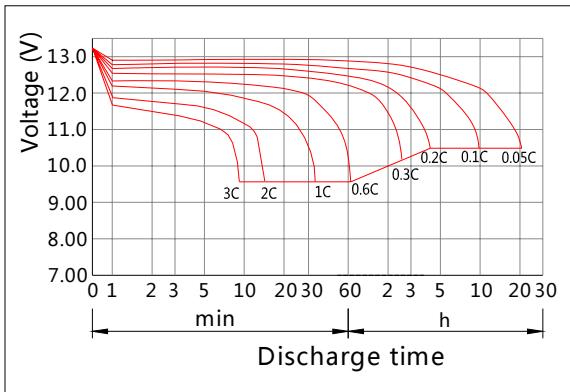

Charging Characteristics(25°C)

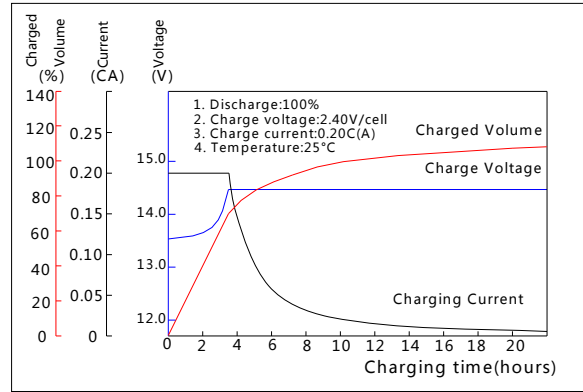

Effect of Temperature on Capacity

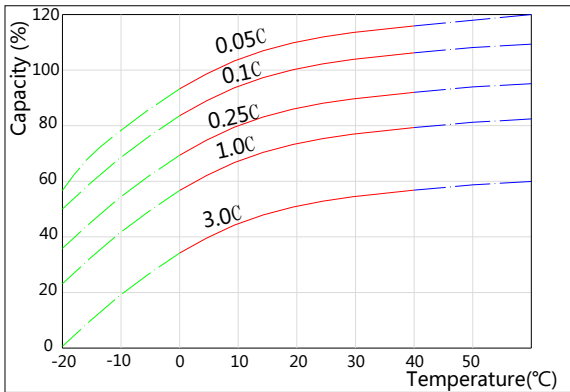

Self-discharge Characteristics

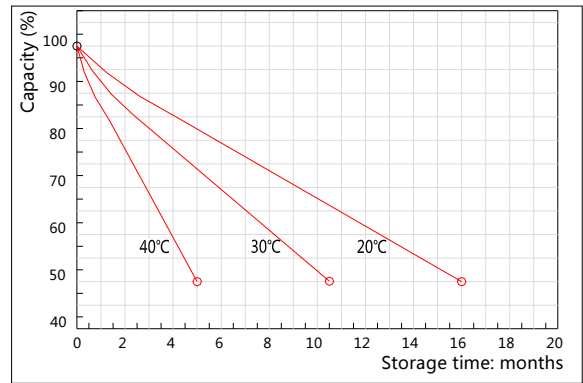

The Relationship for Open Circuit Voltage and Residual Capacity (25°C)

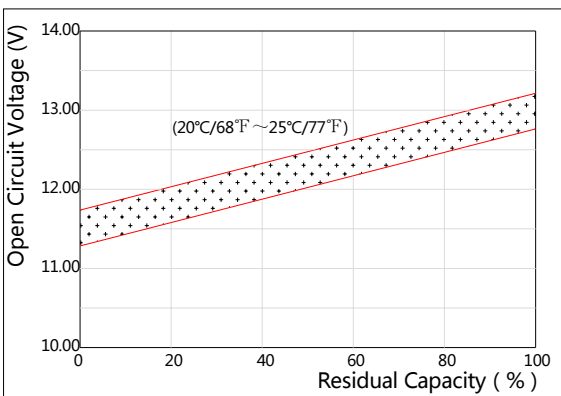

The Relationship for Charging Voltage and Temperature

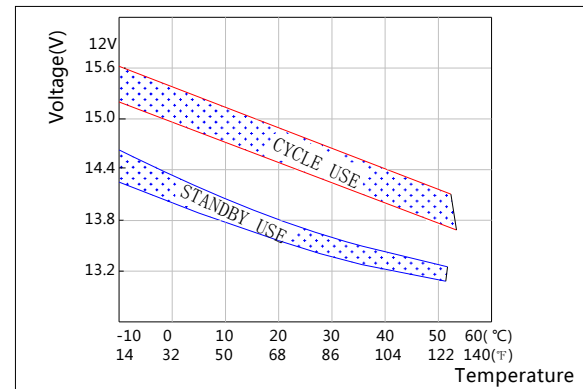

Floating Life on Temperature

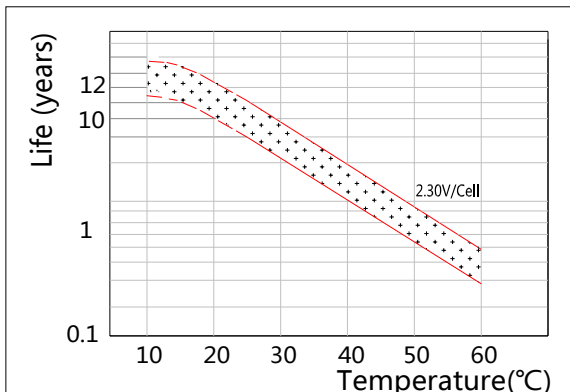

Cycle Life on D.O.D(25°C)

